



/ Scoot 350 / Scoot 350 Mini

The safest solution for parking your scooter

/ GÉNÉRAL

The Scoot rack is an efficient solution for parking push and electric scooters safely. The scooters are placed in the provided holder with edge protection. Thanks to the unique design of the Scoot, the scooters can be fixed to the rack. This makes this solution extremely suitable for parking scooters in public spaces.



/ FEUILLE DE DONNÉES

Structure

- Holder in flat steel (d=3mm)
- Frame in box section (HxWxd=50x50x2mm)

Material

- Steel

Versions

Scoot - Axle distance 350mm

- -Single sided arrangement: 4 / 6 places

Scoot mini - Axle distance 350mm

- Single sided rigging: 4 / 6 places

Attachment possibilities

- Yes

Options

- No available

Dimensions

Single-Sided Scoot

- 4 seats: LxWxH=1410x600x853mm
- 6 places: LxWxH=2110x600x853mm

Single sided Scoot mini

- 4 places: LxBxH=1410x450x453mm
- 6 places: LxBxH=2110x450x453mm

Finishing

- Steel galvanized
- Steel powder coated

Anchoring

- Foot plates
 - with wood screws and nylon plugs on 2 concrete blocks 30x30x40cm
 - Directly on the pavement by means of wedge bolts
 - By chemical anchoring

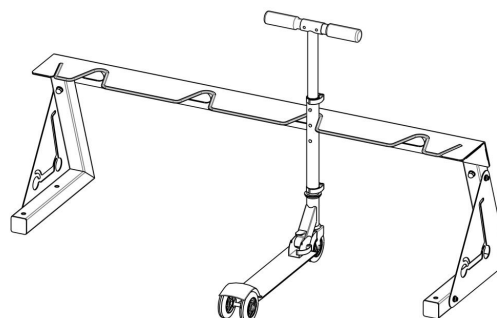
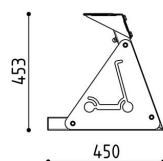
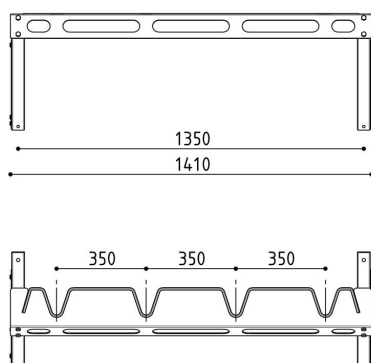
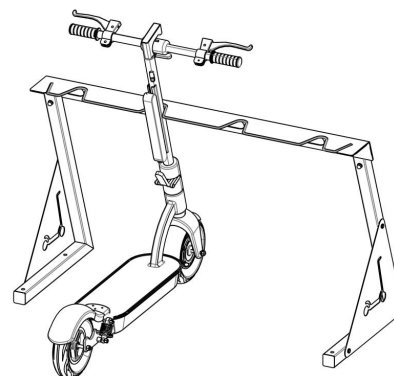
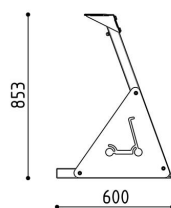
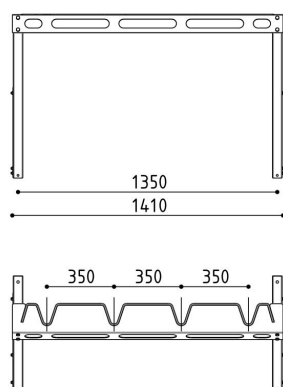

/ INSPIRER

